

Makrolon as transparent solution

- Solutions possible up to 20mm thickness
- Maximum size depending on the wind loads, deflection, construction solution. (Maximum width up to 2050mm and 10000 mm of length.)
- Impact resistance by temperatures far below zero (-100°C)
- Self extinguishing. No ignition. No fire propagation
- Virtually all colours possible
- Can be cold bended
- Hard-coating possible
- Extended UV for high live cycle of the material possible

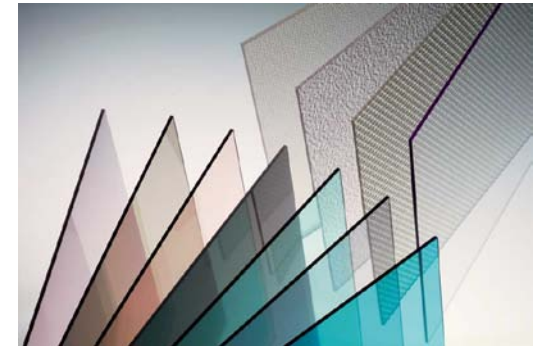

Static's – real life tests

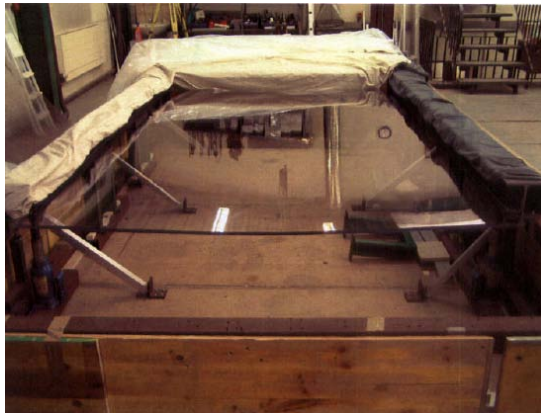
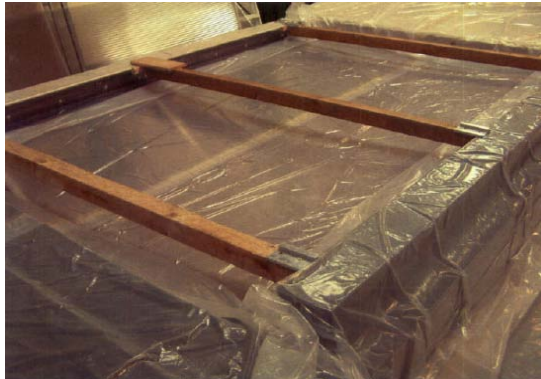

ETAG 10 test report

KPF Kunststoffprüfstelle Franken Datum: 18.03.2007 Seite: 2

Test object possible deviation: none (see annex 1 and 2); not been evaluated regarding to the used angle brackets (85 or 75 mm), which causes three different test series depending on the load direction in combination with the effective number of the sheets.

KUNSTSTOFFPRÜFSTELLE FRANKEN
 Dipl.-Ing. Helmut W. Franke, Betriebsleiter Ingenieur BYJK, VBI
 Abteilung Konstruktion und technischer Kundenkontakt für Automobilbau, Verpackung und Maschinenbau, Transport, Marine und Bauwesen und Kommunikation, Kunststoffverarbeitung
 Dipl.-Ing. K. H. Franke, Geschäftsführer, Dipl.-Ing. H. F. F. Franke
 Steuerberater Europa GmbH
 Hauptstr. 10
 91030 Bamberg
 09302 Germany

Dear Mr. Benz:

Thank you for the information received from Bayer Sheet Europe GmbH with the activities mentioned above.

In view of the advantages of the properties of the support construction, full scale tests according to the European Guidelines ETAG 10/11 were carried out by KPF (Franken) under test no. 17020 for evaluation of the load bearing behaviour ultimate state and serviceability of the sheets.

Construction (UV view 2008, thickness 18 mm)

In construction of a sound barrier wall (see annex 1 to 6).

The rectangular PVC sheets of the dimensions 2000 mm x 2000 mm (width x height) are fastened supported in width on 8700 kg capacity and steel beams 160 mm with a distance of 200 mm. For the horizontal load direction the sheets are fixed in a line by steel angle brackets.

Other load and all of the sheets may have a separation up to 100 mm, which is not supported additionally. The sound barrier wall is fully curved.

The tests were carried out in an uncontrolled test arrangement.

Customer: Bayer AG, 40880 Essen
 Order: 040017020
 Order date: 18.03.2007
 Order ref.: 040017020
 Order ref.: 040017020
 Order ref.: 040017020

Dear Mr. Benz:

Thank you for the information received from Bayer Sheet Europe GmbH with the activities mentioned above.

In view of the advantages of the properties of the support construction, full scale tests according to the European Guidelines ETAG 10/11 were carried out by KPF (Franken) under test no. 17020 for evaluation of the load bearing behaviour ultimate state and serviceability of the sheets.

Construction (UV view 2008, thickness 18 mm)

In construction of a sound barrier wall (see annex 1 to 6).

The rectangular PVC sheets of the dimensions 2000 mm x 2000 mm (width x height) are fastened supported in width on 8700 kg capacity and steel beams 160 mm with a distance of 200 mm. For the horizontal load direction the sheets are fixed in a line by steel angle brackets.

Other load and all of the sheets may have a separation up to 100 mm, which is not supported additionally. The sound barrier wall is fully curved.

The tests were carried out in an uncontrolled test arrangement.

Customer: Bayer AG, 40880 Essen
 Order: 040017020
 Order date: 18.03.2007
 Order ref.: 040017020
 Order ref.: 040017020
 Order ref.: 040017020

Dear Mr. Benz:

Thank you for the information received from Bayer Sheet Europe GmbH with the activities mentioned above.

In view of the advantages of the properties of the support construction, full scale tests according to the European Guidelines ETAG 10/11 were carried out by KPF (Franken) under test no. 17020 for evaluation of the load bearing behaviour ultimate state and serviceability of the sheets.

Construction (UV view 2008, thickness 18 mm)

In construction of a sound barrier wall (see annex 1 to 6).

The rectangular PVC sheets of the dimensions 2000 mm x 2000 mm (width x height) are fastened supported in width on 8700 kg capacity and steel beams 160 mm with a distance of 200 mm. For the horizontal load direction the sheets are fixed in a line by steel angle brackets.

Other load and all of the sheets may have a separation up to 100 mm, which is not supported additionally. The sound barrier wall is fully curved.

The tests were carried out in an uncontrolled test arrangement.

Customer: Bayer AG, 40880 Essen
 Order: 040017020
 Order date: 18.03.2007
 Order ref.: 040017020
 Order ref.: 040017020
 Order ref.: 040017020

Dear Mr. Benz:

Thank you for the information received from Bayer Sheet Europe GmbH with the activities mentioned above.

In view of the advantages of the properties of the support construction, full scale tests according to the European Guidelines ETAG 10/11 were carried out by KPF (Franken) under test no. 17020 for evaluation of the load bearing behaviour ultimate state and serviceability of the sheets.

Construction (UV view 2008, thickness 18 mm)

In construction of a sound barrier wall (see annex 1 to 6).

The rectangular PVC sheets of the dimensions 2000 mm x 2000 mm (width x height) are fastened supported in width on 8700 kg capacity and steel beams 160 mm with a distance of 200 mm. For the horizontal load direction the sheets are fixed in a line by steel angle brackets.

Other load and all of the sheets may have a separation up to 100 mm, which is not supported additionally. The sound barrier wall is fully curved.

The tests were carried out in an uncontrolled test arrangement.

Customer: Bayer AG, 40880 Essen
 Order: 040017020
 Order date: 18.03.2007
 Order ref.: 040017020
 Order ref.: 040017020
 Order ref.: 040017020

To calculate and test the service limit state and user limit state for the (clamping/fixing) system to avoid for example pop-out of the sheets in function of the design needs.

Sound reduction

Measured to standard ISO EN DIN 140-3 as required in the EN 1793

- **Makrolon UV 2099 in 10mm : 34 dB**
- **Makrolon UV 2099 in 12mm : 36dB**
- **Makrolon UV 2099 in 15mm : 36dB**





Noise barrier, Izmir (Turkey)

Year:

2007

Material:

Makrolon UV clear

15 mm



Noise barrier, Krispijn (Netherlands)

Year:

2007

Material:

Makrolon AR

12 mm

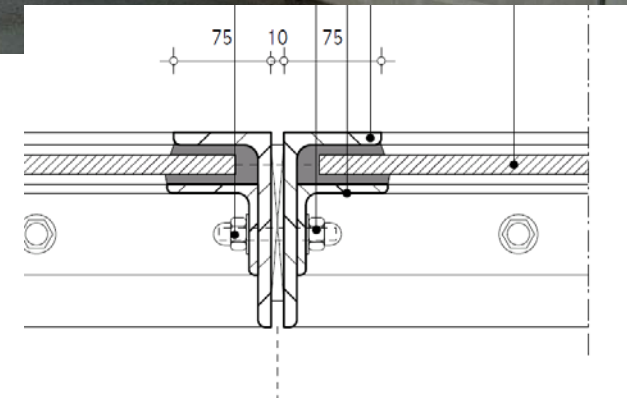
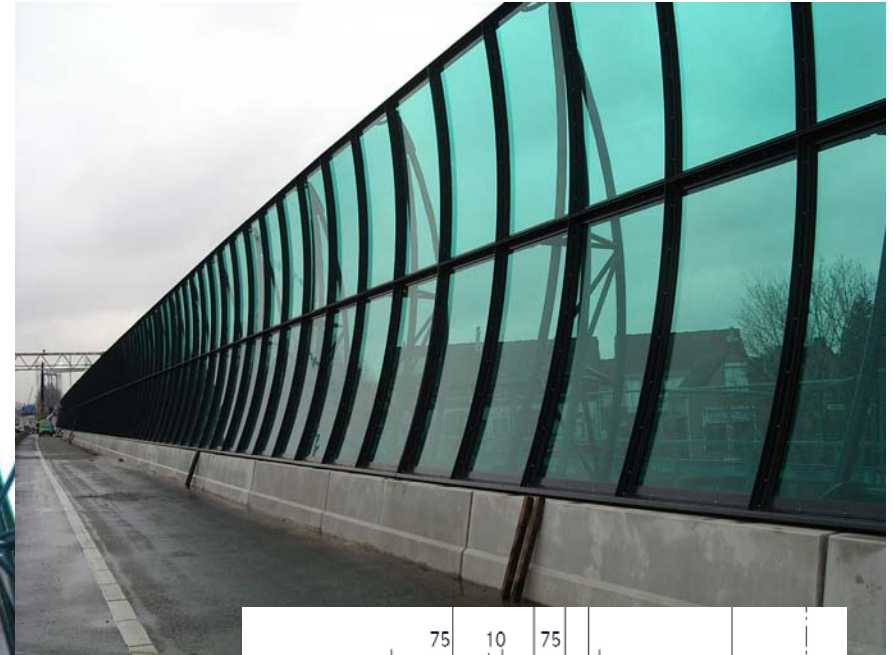

Noise barrier, Antwerp (Belgium)

Year:

2004

Material:

Makrolon AR

12 mm

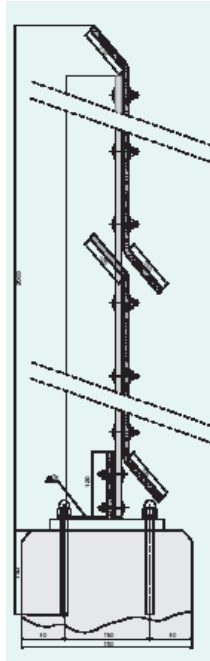

Noise barrier, Seoul (Korea)

Year:

2004

Material:

Makrolon CC

12 mm



Noise barrier, Seoul (Korea)

Year:

2004

Material:

Makrolon UV

12 mm





makrolon®

Noise barrier, Paris (France)

Year:

1995

Material:

Makrolon UV

10 mm



